

Service Schematics

Introduction

Important:

This document is intended for use by authorized service centers only.

“Service Schematics” was created with focus on customer care.
The purpose of this document is to provide further technical repair information for NOKIA mobile phones on Level 3/4 service activities.
It contains additional information such as e.g. “Component finder”.

Saving process time and improving the repair quality is the aim of this document.
It is to be used additionally to the service manual and other training or service information such as Service Bulletins.

While every endeavour has been made to ensure the accuracy of this document, some errors may exist. If the reader finds any errors, NOKIA should be notified in writing.

Please send E-Mail to: TrainingAndVendor.Development@nokia.com

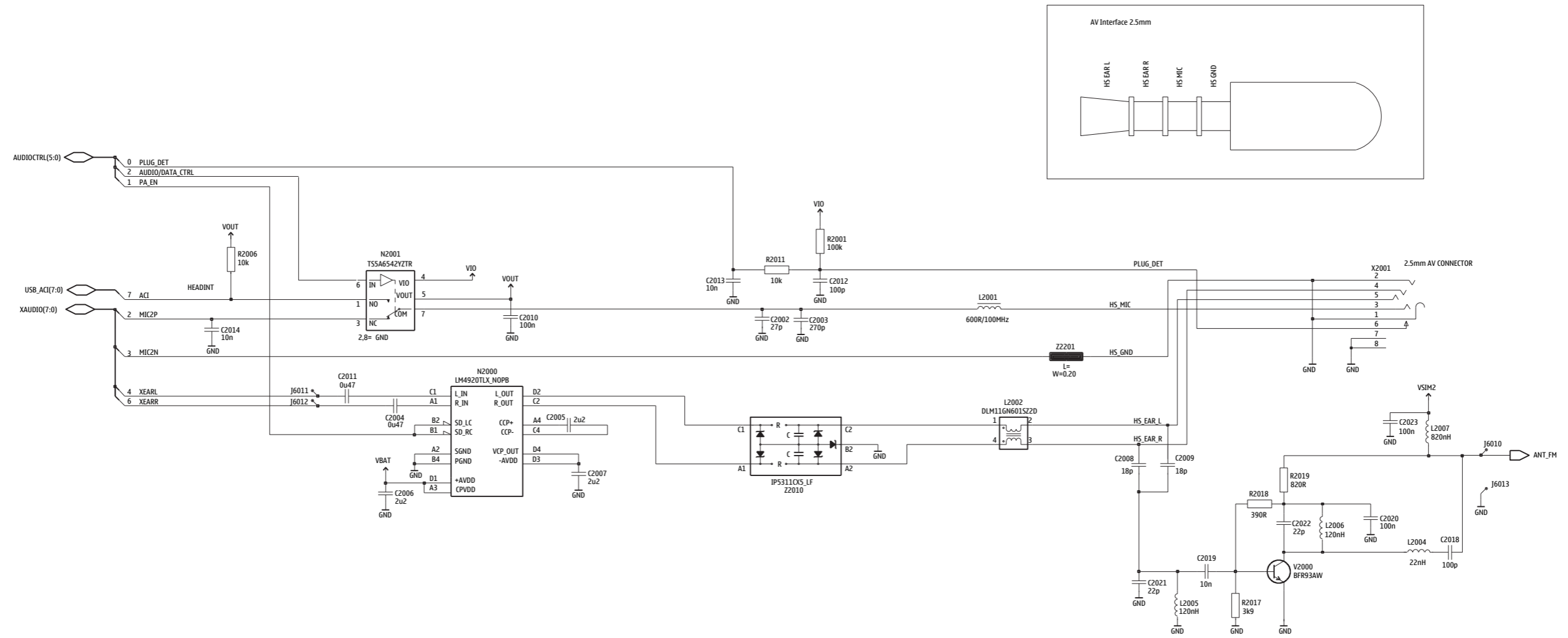
NOKIA 6120c

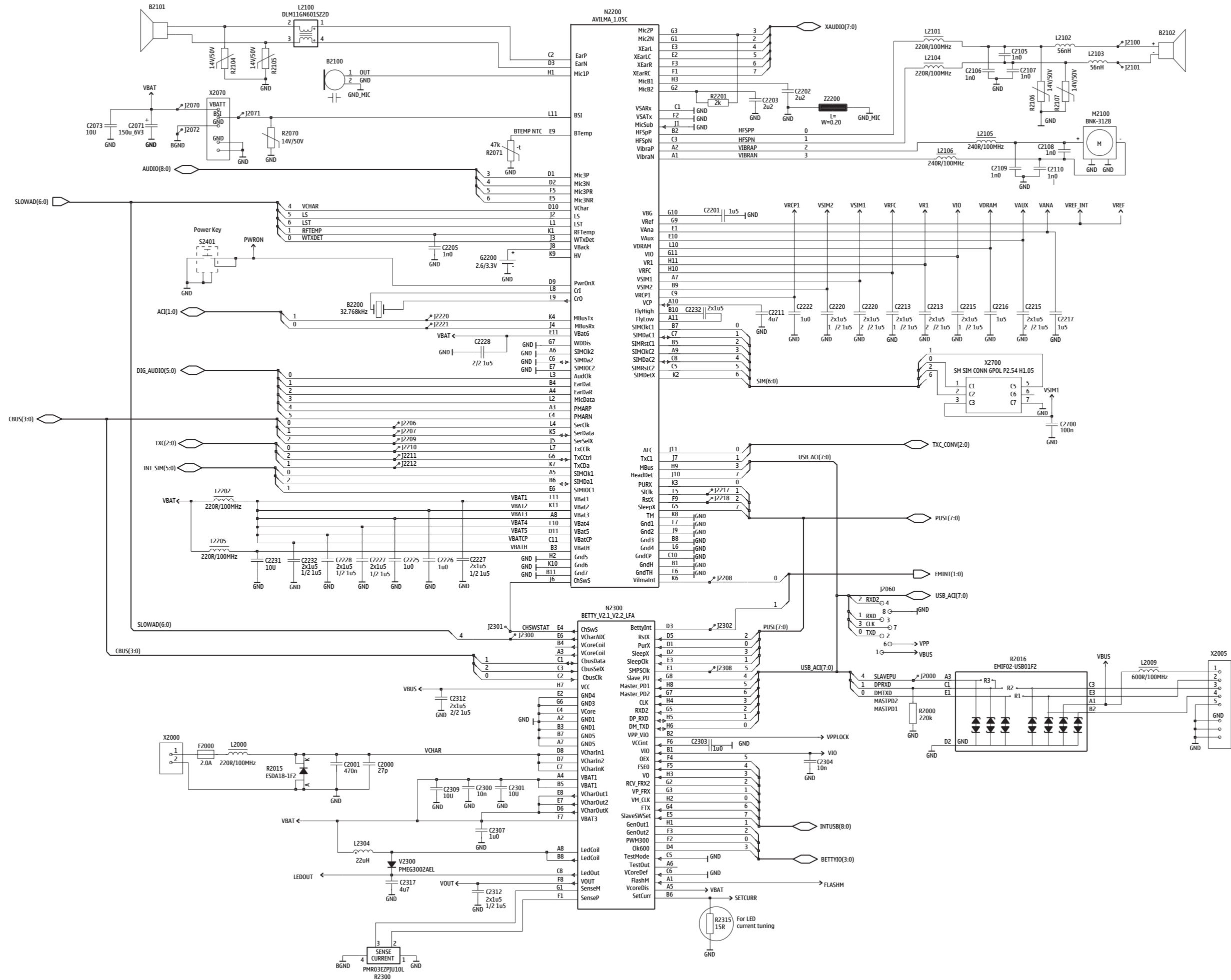
RM-243

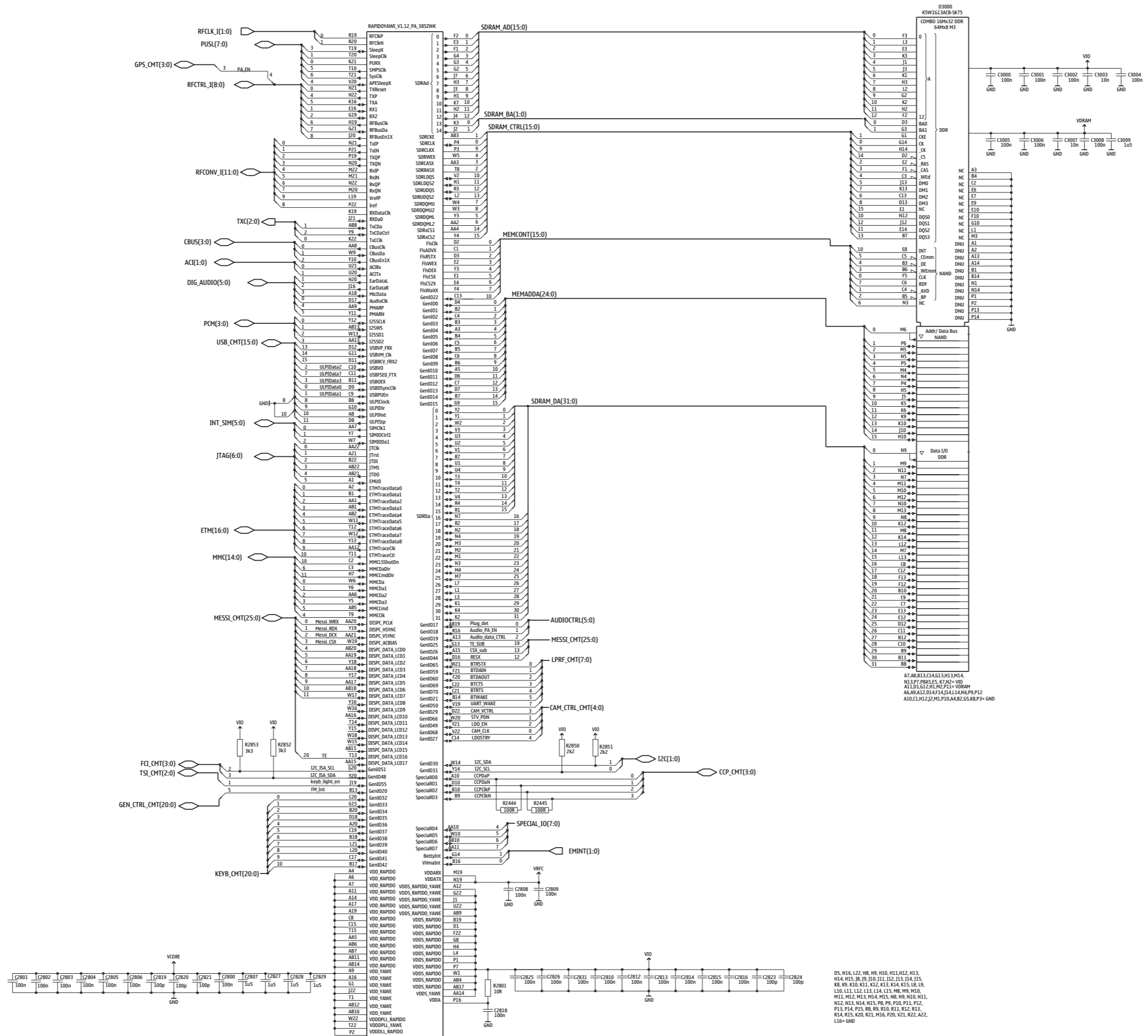


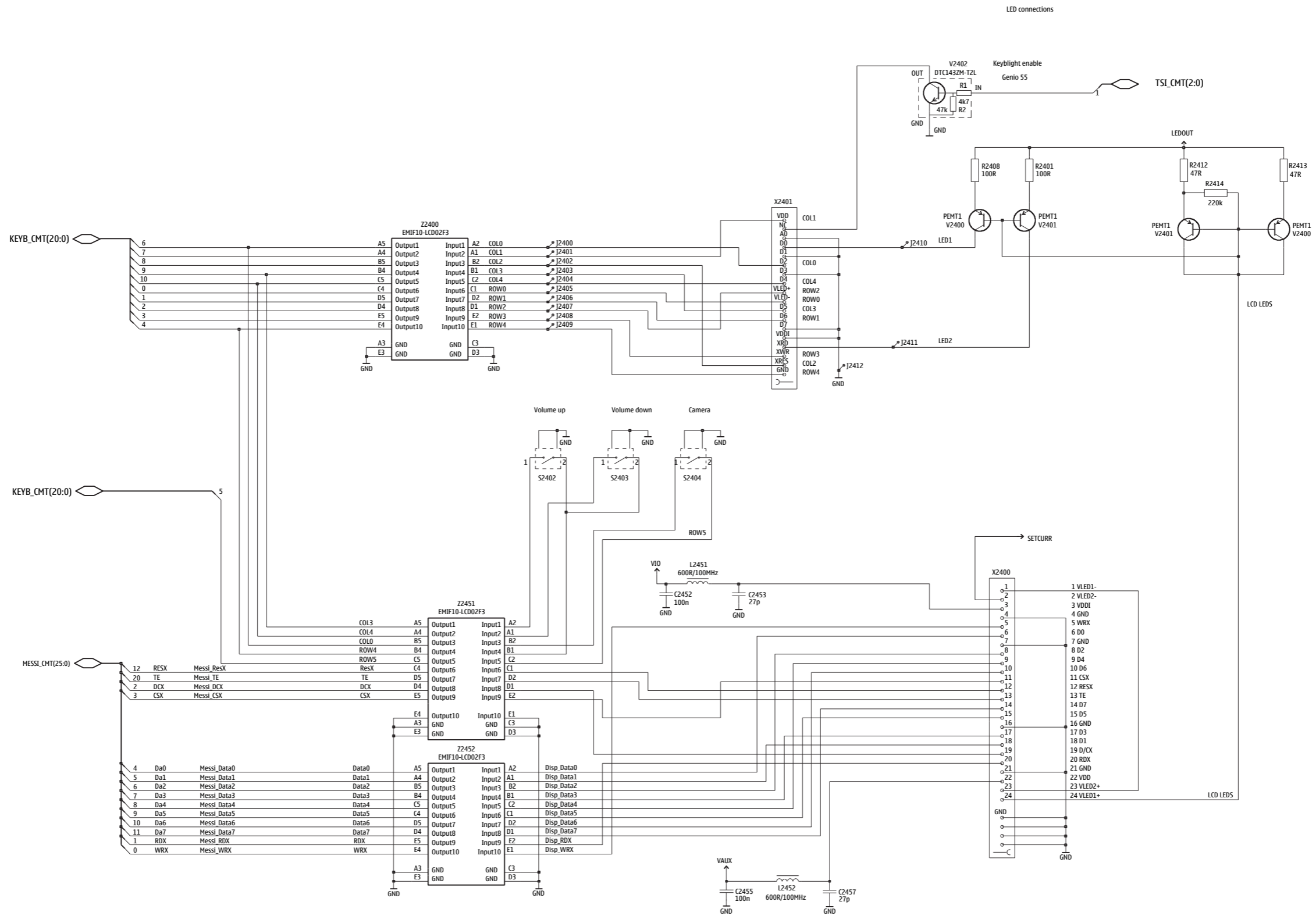
Table of contents	
Frontpage	1
AV connector	2
AVILMA & BETTY	3
RAPIDOYAWE & Combo memory	4
User interface	5
Camera, Bluetooth & FM radio	6
RF - part	7
Component finder	8

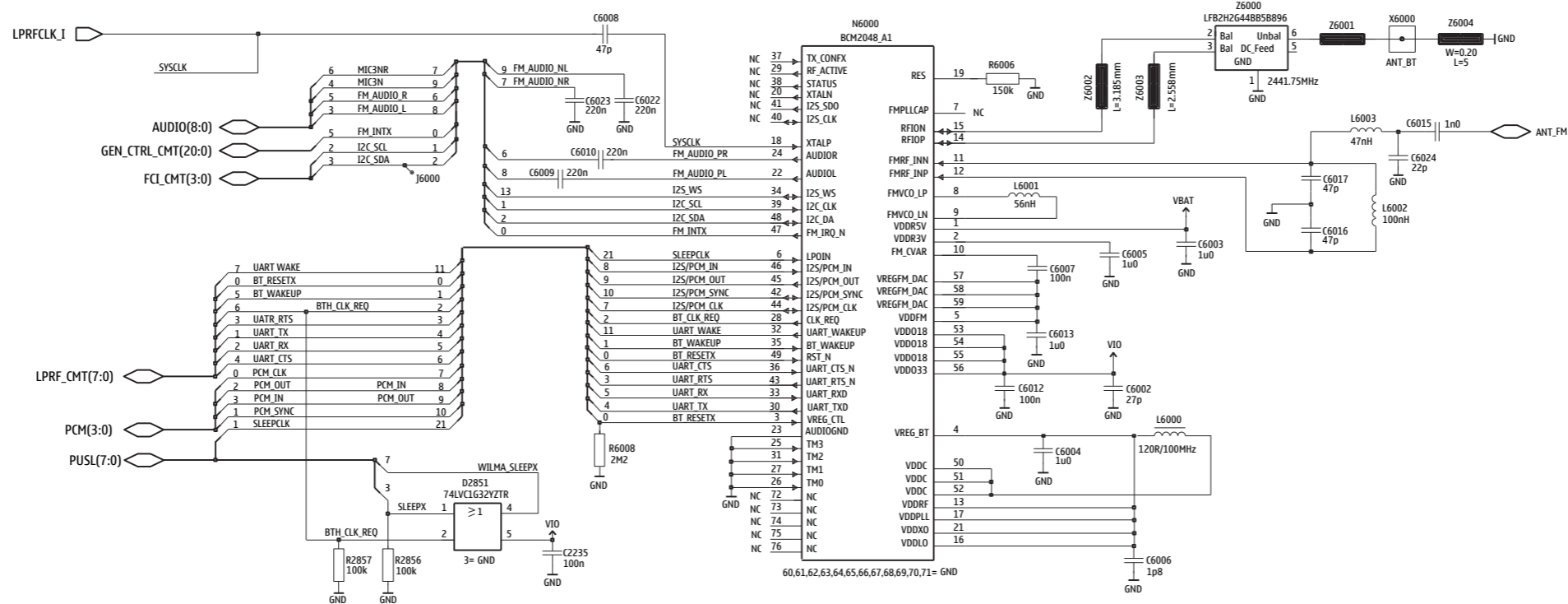
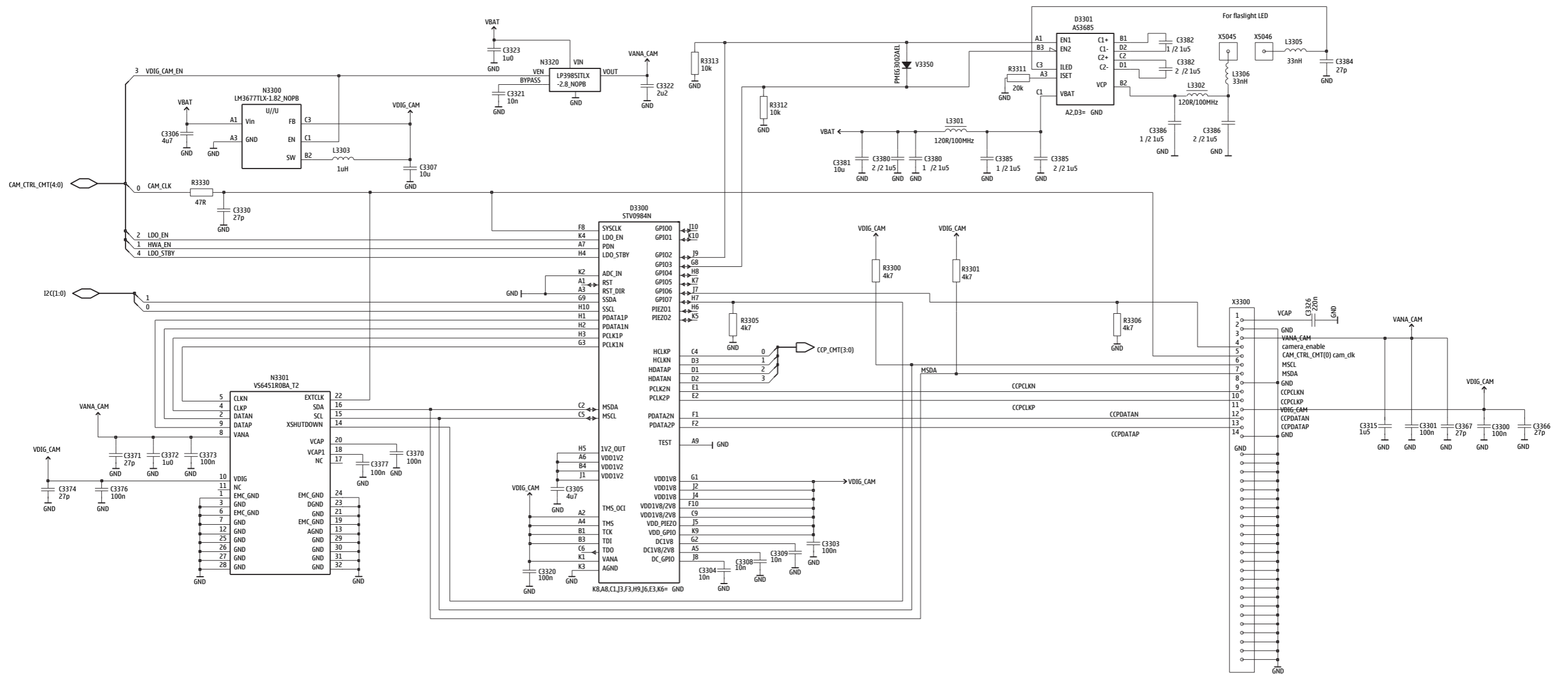
Copyright © NOKIA
This material, including documentation and any related computer programs is protected by copyright, controlled by NOKIA. All rights are reserved. Copying, including reproducing, modifying, storing, adapting or translating any or all of this material requires the prior written consent of NOKIA. This material also contains confidential information, which may not be disclosed to others without the prior written consent of NOKIA.

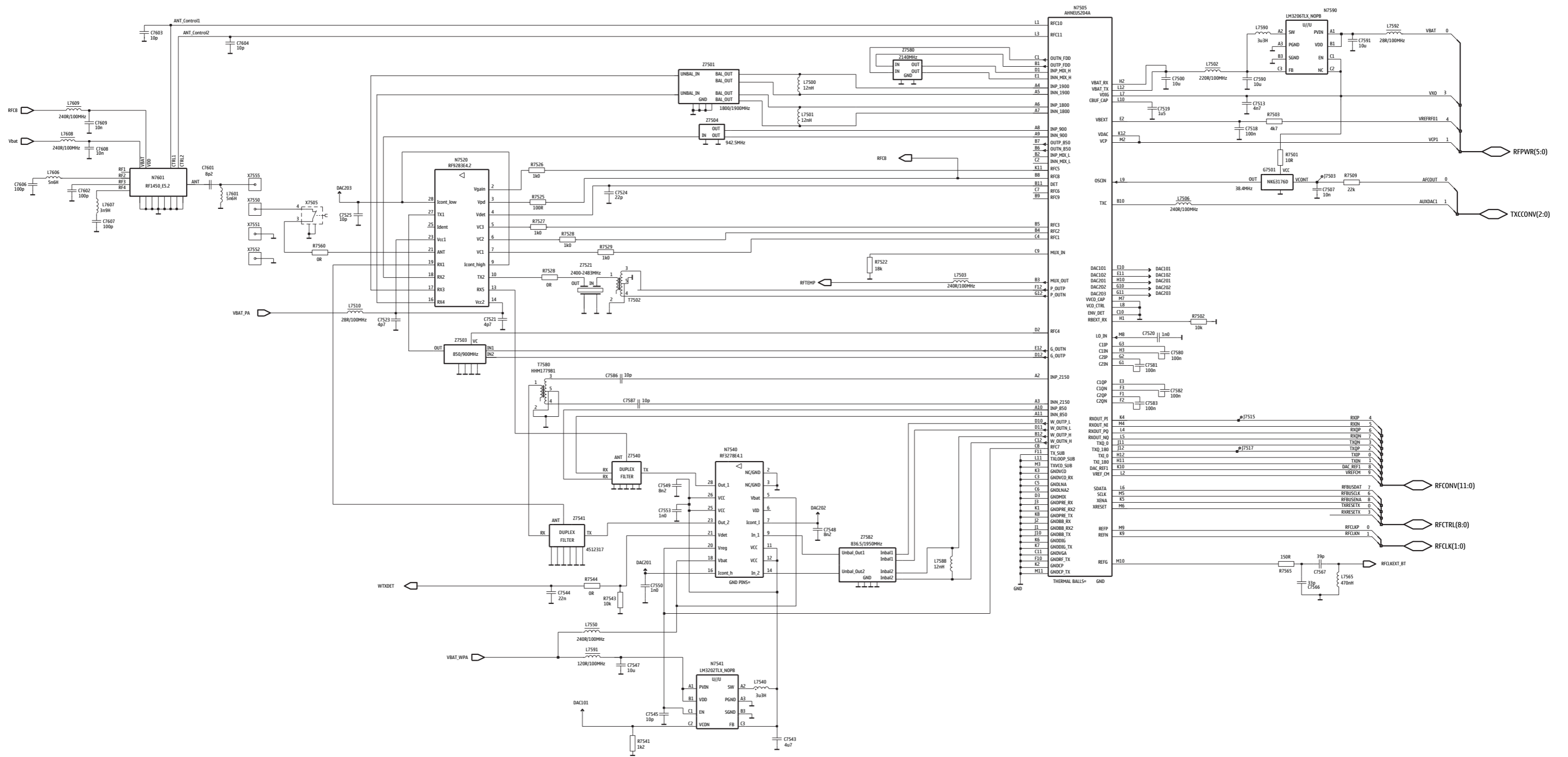












B	C2700	Q6	C3330	J7	C7604	B3	L7592	C4	R3312	F8	
B2200	P7	C2800	J4	C3366	I5	C7606	B2	L7601	A4	R3313	F8
C	C2801	L6	C3367	F4	C7607	A2	L7606	B3	R3330	J6	
C2000	S7	C2802	J5	C3370	B2	C7608	B4	L7607	A3	R6006	Q3
C2001	S7	C2803	L5	C3371	F5	C7609	A2	L7608	B4	R6008	R4
C2002	P4	C2804	L5	C3372	F6	D	L7609	B2	R7501	D1	
C2003	P4	C2805	L5	C3373	F6	D2800	K5	M	R7502	D2	
C2004	N4	C2806	J4	C3374	F4	D2851	P6	M2100	S3	R7503	D3
C2005	N3	C2807	J6	C3376	F4	D3000	K2	N	R7509	C2	
C2006	N4	C2808	K6	C3377	B2	D3300	J7	N2000	N4	R7522	C3
C2007	O3	C2809	K6	C3380	E7	D3301	F7	N2001	P5	R7528	B5
C2008	P4	C2810	K4	C3381	E8	F	N2200	O7	R7541	D8	
C2009	P4	C2811	L4	C3382	E7	F2000	S6	N2300	Q7	R7543	D7
C2010	P4	C2812	J5	C3384	F8	G	N2390	K8	R7544	D7	
C2011	N4	C2813	L5	C3385	F7	G2200	O4	N3200	N2	R7560	D6
C2012	R4	C2814	L6	C3386	F7	G7501	C2	N3300	L7	R7565	P1
C2013	Q5	C2815	J4	C6002	Q2	L	N3301	B3	S		
C2014	P5	C2816	L6	C6003	P2	L2000	S6	N3320	F7	S2401	A5
C2018	P3	C2817	J4	C6004	P3	L2001	Q5	N6000	Q3	S2402	D9
C2019	O2	C2818	J6	C6005	P2	L2002	P4	N7505	D2	S2403	G9
C2020	O2	C2819	J5	C6006	R3	L2004	P2	N7520	D5	S2404	P9
C2021	O3	C2820	L5	C6007	P3	L2005	O3	N7540	C7	T	
C2022	P2	C2821	K6	C6008	R3	L2006	P2	N7541	D7	T7502	B4
C2023	O3	C2822	L6	C6009	R3	L2007	P3	N7590	C3	T7580	D4
C2071	H8	C2823	L4	C6010	R2	L2009	T3	N7601	B3	V	
C2073	H8	C2824	K6	C6012	P2	L2100	B7	R	V2000	O2	
C2105	F3	C2825	K4	C6013	R2	L2101	N6	R2000	T3	V2300	Q7
C2106	E3	C2826	L4	C6015	P4	L2102	E2	R2001	Q4	V2400	R6
C2107	E3	C2827	J6	C6016	Q3	L2103	E4	R2006	P5	V2401	R6
C2108	R4	C2828	J6	C6017	P3	L2104	N6	R2011	R5	V2402	Q6
C2109	R4	C2829	J6	C6022	Q2	L2105	P5	R2015	S6	V3350	F8
C2110	T4	C2830	K7	C6023	Q3	L2106	P6	R2016	T3	X	
C2201	O7	C2831	K4	C6024	P4	L2202	P8	R2017	O2	X2001	T5
C2202	O6	C3000	M3	C7500	C1	L2205	N6	R2018	O2	X2005	T3
C2203	O5	C3001	M2	C7507	C2	L2304	R8	R2019	P3	X2060	R9
C2205	O6	C3002	J3	C7513	D1	L2390	L8	R2070	H7	X2070	H7
C2211	N7	C3003	J2	C7518	D3	L2451	O3	R2071	T4	X2400	N3
C2213	O7	C3004	J2	C7519	D1	L2452	N4	R2104	A7	X2401	S5
C2215	O8	C3005	M2	C7520	D1	L3301	E7	R2105	B7	X2700	P6
C2216	O8	C3006	M2	C7521	D6	L3302	F7	R2106	E2	X3200	P3
C2217	O6	C3007	J2	C7523	C6	L3303	L7	R2107	E3	X3300	H5
C2220	N7	C3008	M3	C7524	D4	L3305	F7	R2201	O6	X5045	G8
C2222	N8	C3009	J3	C7525	D4	L3306	F7	R2300	H6	X5046	G7
C2225	P8	C3100	J4	C7543	D7	L6000	P2	R2315	Q7	X6000	S7
C2226	P8	C3200	N2	C7544	D8	L6001	P3	R2401	Q6	X7505	B6
C2227	O7	C3201	N3	C7545	D8	L6002	P3	R2408	Q5	X7550	A7
C2228	O7	C3204	N3	C7547	D8	L6003	Q4	R2412	Q6	X7551	A8
C2231	N6	C3205	N3	C7548	D8	L7500	D3	R2413	R5	X7552	A7
C2232	N7	C3206	O2	C7549	C7	L7501	D3	R2414	R6	X7555	A4
C2235	P6	C3300	I6	C7550	D8	L7502	C3	R2444	K7	Z	
C2300	Q8	C3301	F4	C7553	C7	L7503	D2	R2445	K7	Z2010	O4
C2301	Q7	C3303	J8	C7566	P1	L7506	B2	R2801	J6	Z2400	M4
C2303	Q6	C3304	J8	C7567	Q1	L7510	B6	R2850	J5	Z2451	O2
C2304	P7	C3305	K8	C7580	D1	L7525	D4	R2851	J6	Z2452	N2
C2307	Q7	C3306	L7	C7581	D1	L7526	D4	R2852	J5	Z6000	Q3
C2309	Q8	C3307	L7	C7582	D1	L7527	D5	R2853	L6	Z7501	D4
C2312	Q6	C3308	K7	C7583	D2	L7528	D5	R2856	P6	Z7503	C4
C2317	R7	C3309	J7	C7586	D3	L7529	D5	R2857	P6	Z7504	C3
C2391	L8	C3315	F4	C7587	D3	L7540	D7	R3201	N3	Z7521	B5
C2393	J8	C3320	J7	C7590	B3	L7550	D8	R3300	K7	Z7540	C6
C2452	O3	C3321	F6	C7591	C3	L7565	Q1	R3301	K7	Z7541	C6
C2453	O3	C3322	E7	C7601	B4	L7588	C3	R3305	J7	Z7580	D3
C2455	N4	C3323	F7	C7602	A3	L7590	C4	R3306	J7	Z7582	C2
C2457	N4	C3326	F5	C7603	A2	L7591	D8	R3311	F7		

